



BMK-15Ea (Cummins)
BMK-16Ea (International)
BMK-17Ea (Duramax)

U.S. Patent #5,298,158

Dual Remote Filtration System Installation and Servicing Instructions

IMPORTANT NOTICE

Read **all** instructions completely before attempting to install this unit. Improper installation could result in serious system and/or equipment damage. The installation of this system is not difficult, however, some mechanical ability is necessary. If you are not comfortable with the instructions or have questions, **do not attempt the installation**. Consult a mechanic or contact AMSOIL INC. for further instructions or assistance.
WARNING: Extreme care should be taken to avoid bodily harm during installation. Before starting, ensure the engine is cool to avoid burns and **never** work in the engine compartment area with the engine running.

A. Getting started

1. Check all parts against the parts list and inspect for damage.
2. Make sure you have the tools needed for the job.

Recommended tool list

Adjustable wrench	5/16" Allen wrench	Vice
Torque wrench	Drill	Drain oil pan
7/16" wrench (2)	1/4" drill bit	Adjustable filter wrench
7/8" wrench (2)	Center punch	Side cutter
15/16" wrench	Hammer	Utility knife

B. Attaching the filter mount

1. Survey the engine compartment for possible mounting locations. The mount should be located as close to the existing full-flow filter as possible. Solid structures such as the firewall, fender well, radiator support or frame are common locations. (**Do not mount on engine.**) Refer to diagram A for minimum area requirements and consider accessibility for servicing.
2. The filter mount can be rotated 180° in its mounting brackets. This allows the oil supply and return hoses to enter the mount on either the right or left hand side. Choose the side that will minimize the need for bends in the hoses. Also refer to diagram C for preferred mounting angle positions.
3. When the location has been determined, use the mounting template provided to locate and mark mounting holes. This can be easily done with a center punch and hammer.
4. With a 1/4" drill bit, drill out the previously marked mounting holes and attach the two piece mount bracket. Use the 4 - 1" long 1/4" bolts, nuts, small washer and fender washers provided. Note the assembly diagram B for details. Using two 7/16" wrenches or socket, tighten to 8 foot pounds.
5. Apply thread sealant onto the two "O" ring adapter fittings (BP-189) as noted in diagram E. Install fittings in mount end adjacent to the arrows. Using a 7/8" wrench, tighten to 40-43 foot pounds. If desired, optional 90° angle fittings (BK-11) or 45° angle fittings (BK-12) may be installed at this time. Sold in packages of two, they are available from AMSOIL INC. **Do not** use thread sealant on either end of the angle fittings, tighten to 525-575 inch pounds or from finger tight, rotate an additional 60° or 1/6 of a turn. Keep in mind the direction you wish to have the hoses intersect the mount.
6. Apply thread sealant as noted in diagram E to the Allen head "O" ring plug (BP-191). Using a 5/16" Allen head wrench, install plug in remaining mount port and tighten to 40-43 foot pounds. **Note:** If optional oil sampling valve is to be used, refer to diagram B and install in place of the Allen head "O" ring plug. Apply thread sealant to the external threads on all components in the BK-13 kit.

7. Attach the filter mount to the mounting brackets using 4-1 1/2" long 1/4" bolts, nuts and washers provided. **Warning:** The bolts **must** be installed so that the nuts are on the side opposite the filter nipples. Failure to do this will result in the bolts hitting the oil filters. Using two 7/16" wrenches or socket, tighten to 8 foot pounds.

C. Oil Supply

1. Apply thread sealant, as noted in diagram E on the two fitting adapters (BP-201). Using a 7/8" wrench, install the two adapter fittings into the Spin-On filter adapter (BP-176 Cummins, BP-177 International, BP-219 Duramax). Tighten to 28 foot pounds or 2-3 turns beyond finger tight. If desired, use optional BK-11 or BK-12 angle fittings.
2. Using a drain oil pan to control any loss of oil, remove the existing engine full-flow oil filter. Clean the gasket seating area on the engine with a clean lint free cloth.
3. Install the spin-on filter adapter in place of the old oil filter. To ensure proper sealing and aid in installation, place a small amount of grease on both sides of the "O" ring used. Tighten the adapter one full turn after adapter first contacts sealing surface, back off slightly, about 1/8".

D. Oil feed and return lines

- Note:** The hose and hose fittings supplied with this kit have been matched to provide maximum performance and life expectancy. Interchanging with other types or brands is **not recommended** and **should be avoided**. Should additional hose be required, it may be obtained from AMSOIL INC. by ordering part number BP-250.
1. (Oil supply hose) Measure the amount of hose (BP-250) you will need to run from the **Red** colored port (labeled **Out**) on the spin-on adapter to the port with the arrow pointing **In**, on the filter mount. Additional length will be required to accommodate engine movement during operation. Also consider how the hose will be routed. Make sure the hose does not contact any hot or moving surfaces or sharp edges. Ensure a minimum bend radius of 1 1/2" is maintained at all corners. Also, bends in hose should not begin at hose fittings. See diagrams D and G for additional details.
 2. Using a utility knife, squarely cut the hose to the proper length.
 3. Install hose fittings (BP-260) on both ends of the hose. Follow the instructions noted in diagram F. Tools required are one 7/8" wrench and one 15/16" wrench or vise. **Note:** Do not use any form of thread sealant anywhere on the BP-260 hose fittings.
 4. Route the hose assembly as noted in D.1 and connect the hose fittings. **Note:** Optional 90° or 45° angle fittings may be installed at this time between the hose fittings and spin-on-adapter (see instruction B-5).
 5. Using two 7/8" wrenches, tighten hose fitting swivel nuts and swivel nuts on angle fittings (if used) to 525-575 inch pounds or from finger tight, rotate an additional 60° or 1/6 of a turn. **Note:** Do not use any form of thread sealant anywhere on the hose or angle fittings.
 6. (Oil return hose) Repeat steps D.1 through D.5. Connect hose at port labeled **In** on the spin-on adapter to the port with the arrow pointing **Out**, on the filter mount.
 7. Use plastic ties (BP-46) to secure hose in position and away from damage. Trim ties using side cutter. **Note:** Over tightening the plastic ties may cause the hose to collapse and restrict oil flow.
 8. Fill the provided Full-Flow and By-Pass Filters with the same motor oil being used in the vehicle. Lubricate the filter gasket with oil and spin filter onto mount. Tighten per instructions on the filter can.

E. Start up procedures

1. Check that all fittings and hoses are securely attached, and that the hoses are routed properly.
2. Check engine oil level. Fill to full mark if necessary.
3. Set vehicle parking brake, With transmission in park/neutral start the engine and immediately check oil pressure. Note: Pressure may initially take a moment or two to rise.
Caution: Carefully check for leaks at fittings, hoses and mount. If leaks are observed, **STOP ENGINE IMMEDIATELY**, repair leaks and continue.
4. After engine has warmed, shut off and re-check engine oil level. Fill as necessary.
5. Record vehicle mileage/operating hours and date of installation.

Diesel Powered Engines: Due to higher oil contamination levels in diesel engines and variance in fuel quality, maintenance intervals for the filter element and oil change intervals should be determined using oil analysis. For more on oil analysis see the last page.

F. Periodic maintenance

1. Periodic visual inspection of the fittings and hoses is recommended. Look for leaks, hose deterioration and cuts. Repair and/or replace as necessary.
2. To change the filter element:
 - a. Ensure engine is off and use caution as the engine, oil and filter may be hot and could result in an injury.
 - b. Using a filter wrench, remove the filter elements. Dispose of properly.
 - c. Clean the filter gasket contact areas on the mount with a clean, lint-free rag.
 - d. Lubricate the new filter gaskets with clean oil or grease.
 - e. Fill filters as full as possible with engine oil.
 - f. Screw on new filters, tighten per instructions on filter can.
 - g. Start engine and check for leaks.
 - h. Check engine oil level, fill as needed.
3. Record vehicle mileage/operating hours for future reference.

Parts and assembly list

Item	Description	Qty.	Part No.
1.	Filter Mount Assembly	1	BK-209
2.	Allen Head Plug	2	BP-191
3.	1/4" 20 x 1" Hex Head Bolt	4	BP-23
4.	1/4" I.D. Washer	6	BP-21
5.	1/4"-20 Self Locking Nuts	8	BP-22
6.	Adapter Fitting 1/2 NPT-1/2 JIC	2	BP-201
7.	Hose Fitting	4	BP-260
8.	1 3/32" I.D. Hose	8'	BP-250
9.	Spin-On Casting (Cummins) with "O" ring	1	BP-176
	Spin-On Casting (International) with "O" ring	1	BP-177
	Spin-On Casting (Duramax) with "O" ring	1	BP-219
10.	"O" Ring 2 1/2" I.D. (Cummins, Duramax)	1	BP-161
	"O" Ring 3 5/8" I.D. (International)	1	BP-178
	"O" Ring 3 1/8" I.D. (Duramax)	1	BP-162
11.	"O" Ring Fitting Adapter 3/4"-16 x 1/2" JIC	2	BP-189
12.	Mounting Bracket (top)	1	BP-194
13.	Mounting Bracket (bottom)	1	BP-195
14.	1/4"-20 x 1 1/2" Hex Head Bolt	4	BP-185
15.	1/4" I.D. Fender Washer	4	BP-186
16.	Full-Flow Filter	1	EaO-26
17.	By-Pass Filter	1	EaBP-100
	Plastic Tie	2	BP-46
	Thread Sealant	1	BP-198
	Instruction Sheet	1	BP-174

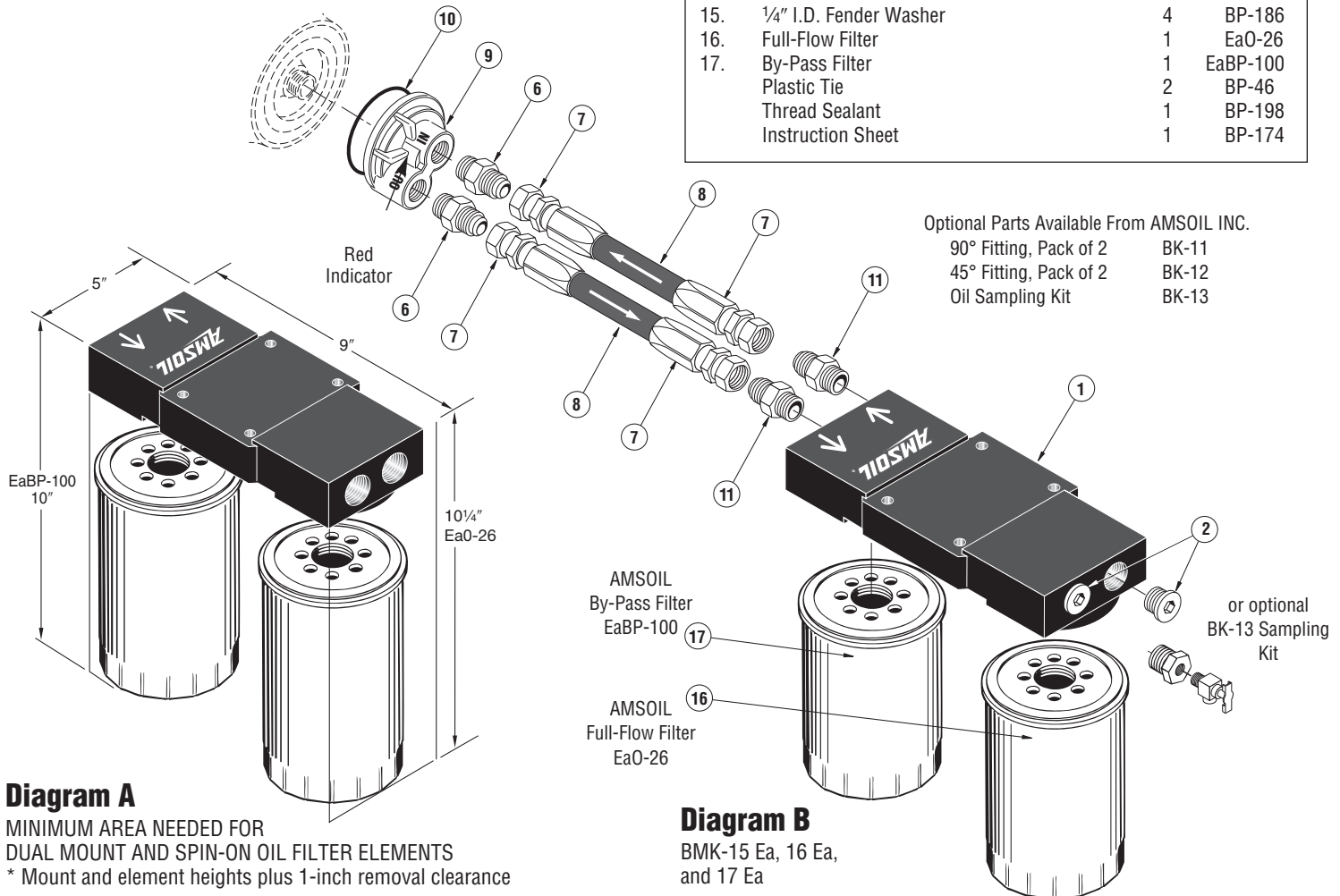
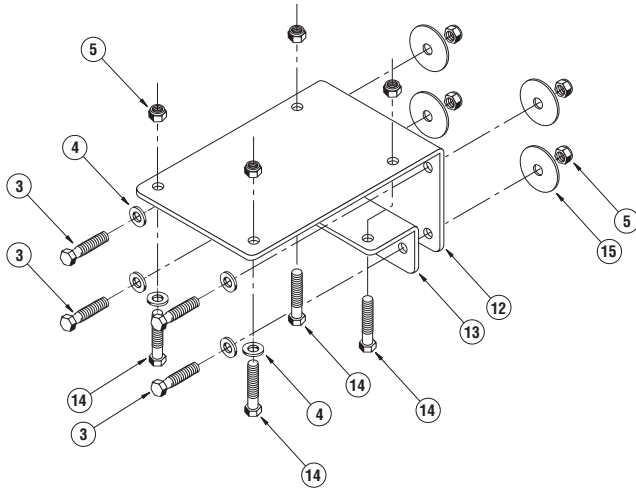

Mounting Angle Diagram C

(Recommendations are the same right to left and front to back)
Mounting angle above horizontal is not recommended

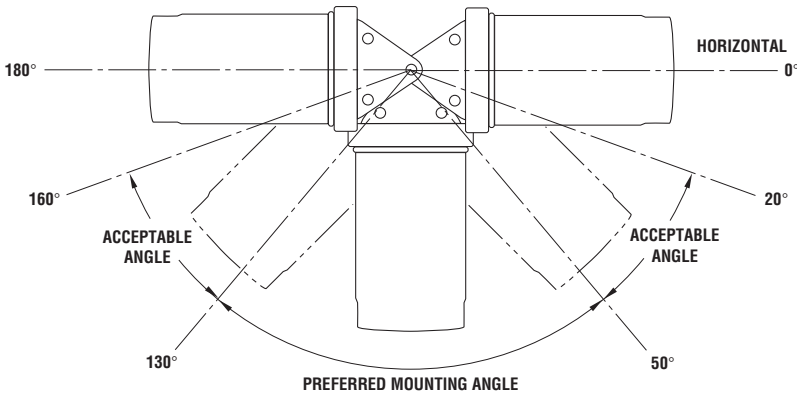

Diagram D

Minimum Bend Radius
(Actual size)

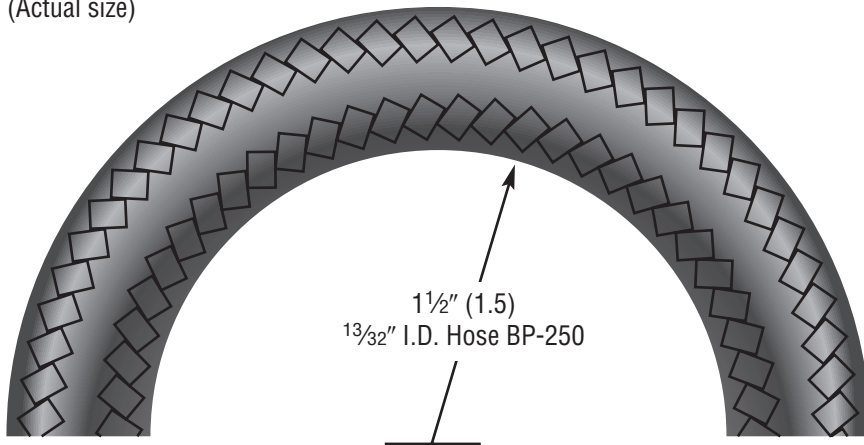
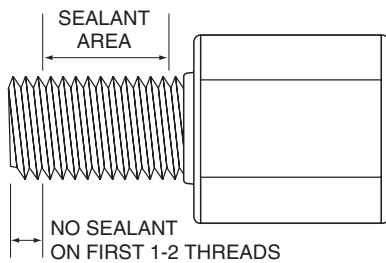

Diagram E



Note: If Teflon tape is used, it should be wrapped no more than 1 1/2 to 2 turns in a clockwise direction when viewed from the thread end.

Caution: More than two turns of tape may cause distortion or cracking of the port. Never back off (loosen) pipe threaded connectors to achieve alignment.

Diagram F



1. Place socket in vice and screw in hose counter-clockwise until hose bottoms. Back hose out 1/2 turn.

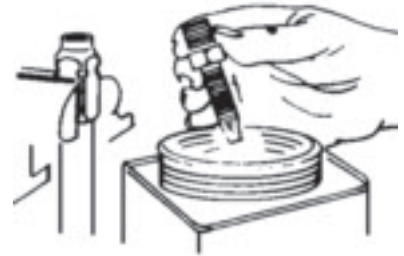

2. Oil inside of hose and nipple threads liberally with oil. Do not oil hose cover.



3. Screw nipple assembly into socket using wrench on nipple hex until nipple hex shoulders against socket.

Mounting Template

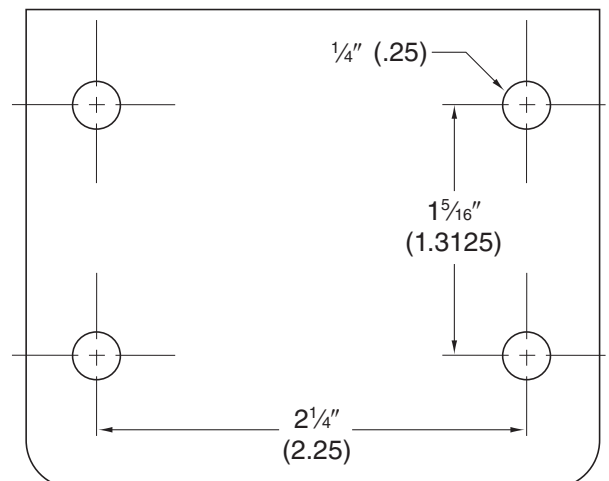

BMK-15Ea, 16Ea & 17Ea: PAGE TWO

(1) **BP-194**
MOUNTING
BRACKET
TOP



(1) **BP-195**
MOUNTING
BRACKET
BOTTOM

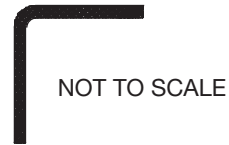

(2) **BP-201**
ADAPTER
FITTING

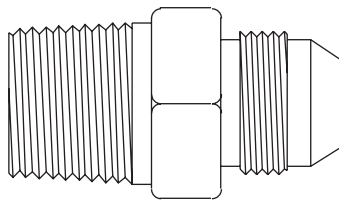

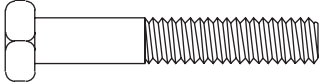

BMK-15Ea, 16Ea & 17Ea PARTS IDENTIFICATION SHEET

(2) BP-46 
PLASTIC TIE

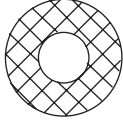
(4) BP-185 
1/4" X 1 1/2"
BOLT

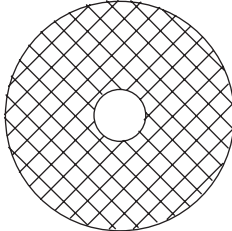
(6) BP-21 
1/4" I.D. WASHER

(4) BP-186 
1/4" FENDER
WASHER

(8) BP-22 
1/4" NUT

(4) BP-23 
1/4" X 1" BOLT

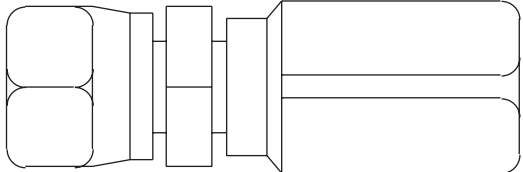
(4) BP-260 
HOSE FITTING

(1) BP-161 
"O" RING 2 1/2" I.D.
(CUMMINS & DURAMAX)
NOT TO SCALE

(8) BP-250 
1 3/32" HOSE
AMSOIL BP - 250

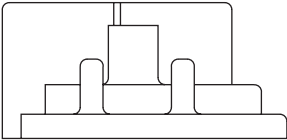
(1) BP-176 
FILTER ADAPTER
(CUMMINS)
NOT TO SCALE

(1) BP-219 
FILTER ADAPTER
(DURAMAX)
NOT TO SCALE

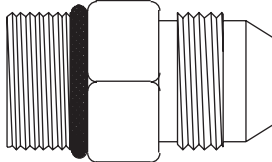
(2) BP-189 
"O" RING
FITTING
ADAPTER

(1) BP-162 
"O" RING 3 1/8" I.D.
(DURAMAX)
NOT TO SCALE

(1) BP-191 
ALLEN HEAD
PLUG

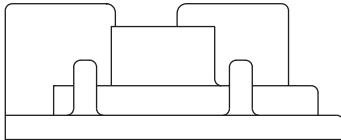
(1) BP-177 
FILTER ADAPTER
(INTERNATIONAL)
NOT TO SCALE

(1) BP-178 
"O" RING 3 5/8" I.D.
(INTERNATIONAL)
NOT TO SCALE

(1) BK-209 
FILTER MOUNT
ASSEMBLY
NOT TO SCALE

Diagram G

1. Provide for length change

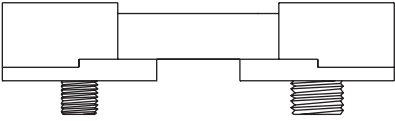
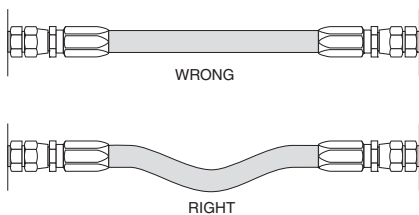

In straight hose installations allow enough slack in the hose line to provide for changes in length that will occur when pressure is applied. This change in length can be from +2% to -4%.

2. Avoid twisting and orient properly

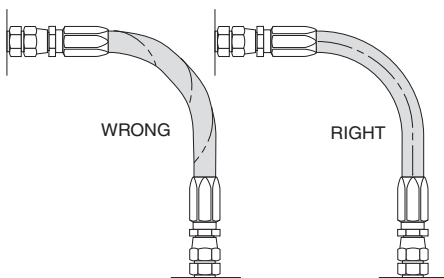

Do not twist hose during installation. This can be determined by the printed layline on the hose. Pressure applied to a twisted hose can cause hose failure or loosening of connections.

3. Protect from hazardous environment

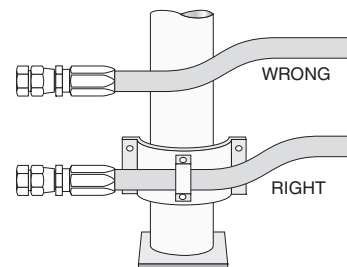

Keep hose away from hot parts. High ambient temperatures will shorten hose life. If you can not route it away from the heat source, insulate it.

4. Avoid mechanical strains

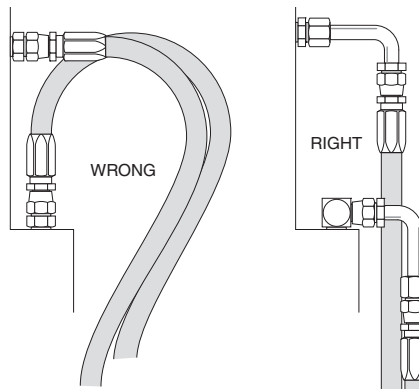

Use elbows and adapters in the installation to relieve strain on the assembly, and to provide easier and neater installations that are accessible for inspection and maintenance.

5. Use proper bend radius

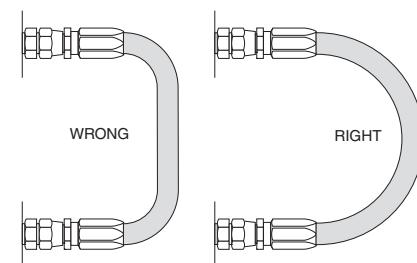

Keep the bend radius of the hose as large as possible to avoid collapsing of the hose and restriction of flow. Follow catalog specs on minimum bend radii.

6. Use proper bend radius (cont.)

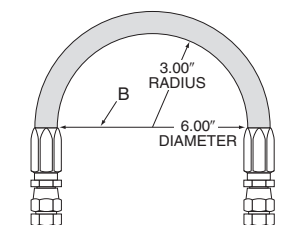

Maximum bend radius is measured on the inside bend of the hose. To determine minimum bend, divide the total distance between ends (B length) by 2. For example B = 6, minimum bend radius = 3.

7. Secure for protection

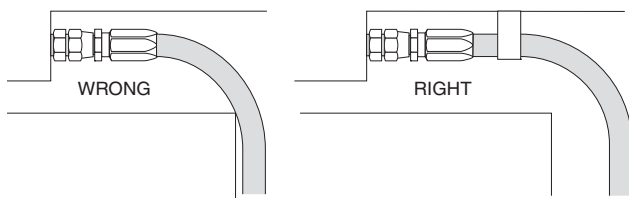

Install hose runs to avoid rubbing or abrasion. Use clamps to support long runs of hose or to keep hose away from moving parts. It is important that the clamps do not allow the hose to move. This movement will cause abrasion and premature hose failure.

8. Avoid Improper Hose Movement

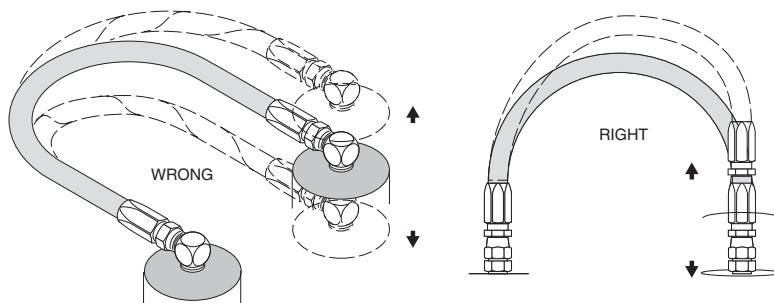

Make sure relative motion of the machine components produces bending rather than twisting of the hose. Hose should be routed so that the flex is in the same plane as the equipment movement.

Diagram H

INSTALLING AN OIL SAMPLING PETCOCK ON THE SPIN-ON BY-PASS:

Getting a clean and uncontaminated oil sample is easy and simple when an oil sampling pet-cock is installed into the Spin-On By-Pass Oil Filter system. This can be easily done by ordering a BK-13.

Installs in place of the BP-191 Allen Head Plug.

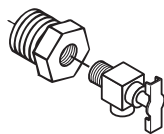

Oil Analysis:

- If installing By-Pass Oil Filter with AMSOIL Air Filter and 100% Synthetic Engine Oil in a pleasure vehicle, we recommend the TRIGARD Oil Analysis Program:
 - TRIGARD 1 (Stock No. ATG-01) is the starter program. It contains material for registration and 2 **prepaid** analysis to check oil's condition.
 - TRIGARD 2 (ATG-02) is for all subsequent oil samples. Each ATG-02 also contains materials for 2 prepaid oil analysis.
- For other oil analysis order G-1318 Oil Analysis Sampling Kits (in U.S., Canada). Consult AMSOIL Technical Service for details.

To order By-Pass Oil Filter Parts or oil sample kits, consult your AMSOIL Dealer or the AMSOIL Product Price List for your country. Most of these items are available from your AMSOIL Product Center.