



BMK-18

U.S. Patent #5,298,158

Marine Dual Remote Filtration System Mounting Kit Installation and Servicing Instructions

IMPORTANT NOTICE

Read **all** instructions completely before attempting to install this unit. Improper installation could result in serious system and/or equipment damage. The installation of this system is not difficult, however, some mechanical ability is necessary. If you are not comfortable with the instructions or have questions, **do not attempt the installation.** Consult a mechanic or contact AMSOIL INC. for further instructions or assistance.

WARNING: Extreme care should be taken to avoid bodily harm during installation. Before starting, ensure the engine is cool to avoid burns and **never** work in the engine compartment area with the engine running.

A. Getting started

1. Check all parts against the parts list and inspect for damage.
2. Make sure you have the tools needed for the job.

Recommended tool list

Adjustable wrench	5/16" Allen wrench	Drill
7/16" wrench (2)	Torque Wrench	1/4" drill bit
13/16" wrench	Side Cutter	Center punch
7/8" wrench (2)	Adjustable filter wrench	Hammer
15/16" wrench	Drain oil pan	Vice

B. Filter selection

Any one of 8 different size AMSOIL Full-Flow Oil Filters and 3 different AMSOIL By-Pass Filters may be used with this mount. Select a full-flow filter that is equivalent or larger than the one originally installed on your vehicle. The larger the filter used, the greater the filtration capacity and the longer the filter life. The By-Pass filter should be the largest for which space is available. Use the dimension information below as well as the data in diagram A to assist you in selecting your filters.

AMSOIL filters

Full-flow	DIA.	Height	By-Pass	DIA.	Height
SDF-26	3.75"	7.04"	BE-110	4.25"	10.375"
SDF-15*	3.75"	5.19"	BE-100	4.25"	7.375"
SDF-96	3.75"	4.25"	BE-90*	4.25"	5.750"
SDF-42	3.75"	3.92"			
SDF-34	2.95"	4.73"			
SDF-84	3.12"	4.00"			
SDF-57	2.95"	3.38"			
SDF-10	2.56"	2.85"			

*Most commonly used filters

1. Survey the engine compartment for possible mounting locations. The mount should be located in the same area as the existing full flow filter. Make sure the mounting structure is adequate to carry the weight of the filtration system.
2. The filter mount can be rotated 180° in its mounting brackets. This allows the oil supply and return hoses to enter the mount on either the right or left hand side. Choose the side that will minimize the need for bends in the hoses or the need for additional hose fittings. Also, refer to diagram B for preferred mounting angle positions.
3. When the location has been determined, use the mounting template provided to locate and mark mounting holes. This can be easily done with a center punch and hammer.
4. With a 1/4" drill bit, drill out the previously marked mounting holes and attach the two piece mount bracket (BP-225). Use the 4 - 1" long 1/4" bolts, nuts, small washer and fender washers provided. Note the assembly diagram D for details. Using two 7/16" wrenches or socket, tightened to 8 foot pounds.
5. Apply thread sealant onto the two "O" ring adapter fittings (BP-232) as noted in diagram E. Install fittings in mount end adjacent to the arrows. Using a 7/8" wrench tighten to 40-43 foot pounds. If desired, optional 90° angle fitting (BK-199) (long) or (BK-200) (short) may be installed at this time. See diagram D. Sold as each, they are available from AMSOIL INC. **Do not** use thread sealant on either end of the angle fittings, tighten to 525-575 inch pounds or from finger tight rotate an additional 60° or 1/6 of a turn. Keep in mind the direction you wish to have the hoses intersect the mount.
6. Apply thread sealant as noted in diagram E to the Allen head "O" ring plug (BP-228). Using a 5/16" Allen head wrench, install plug in remaining mount port and tighten to 40-43 foot pounds. **Note:** If optional oil sampling valve is to be used, refer to

diagram D and install in place of the Allen head "O" ring plug. Apply thread sealant to the external threads on all components in the BK-13 kit.

7. Attach the filter mount to the mounting brackets using 4-1 1/2" long 1/4" bolts, nuts and washers provided. **Warning:** The bolts **must** be installed so that the nuts are on the side opposite the filter nipples. Failure to do this will result in the bolts hitting the oil filters. Using two 7/16" wrenches or socket, tighten to 8 foot pounds.

C. Oil Supply

1. Using device to control any loss of oil, remove the existing engine full-flow filter. Clean the gasket seating area on the engine with a lint free cloth. Take the Spin on Adapter Gasket (BP-196) supplied with the separately sold thread adapter kit and compare it to the filter contact surface on the engine. If the gasket is smaller than the contact surface, you will need to use the "O-ring" Casting (BP-160) and the 3/8" I.D. o-ring supplied. If the gasket fits the contact surface, the o-ring casting and 3/8" I.D. o-ring should not be used.
2. Temporarily assemble the spin-on adapter by sliding the o-ring (BP-246) on to the adapter nut (BP-304, 305, 306, or 307), and then slide the adapter nut into the large center hole of the spin-on adapter. (BP-302) This can be made easier by applying a small amount of oil on the o-ring.
3. Thread the spin-on adapter on to the engine and determine the direction in which you would like the hoses to intersect the adapter. Remove the assembly from the engine.
4. Apply thread sealant, as noted in diagram E on 1 BP-232 and one BP-231 90° fitting. The sealant should be placed on the o-ring side thread only.
5. If you wish to have the hoses intersect the spin-on adapter perpendicular to its top, install the BP-232 straight fitting in the adapter nut and the BP-231 90° fitting on the side of the spin-on adapter, labeled A. Reverse the fitting position if you wish to have the hoses intersect the spin-on adapter parallel to the top of the spin-on adapter.
6. Using a 7/8" wrench, tighten BP-232 straight fitting to 40 - 43 foot-pounds. Thread the BP-231 three full turns and position in desired location. Tighten locking nut on fitting 40 - 43 foot-pounds.
7. Apply a thin coating of oil on the spin-on adapter gasket and the adapter nut o-ring.
8. Reassemble adapter and install on engine using the o-ring casting and 3/8" I.D. o-ring assembly if necessary. Make sure fittings are correctly positioned and tighten adapter nut to 35 - 40 foot-pounds.

D. Oil feed and return lines

Note: The hose and hose fittings supplied with this kit have been matched to provide maximum performance and life expectancy. Interchanging with other types or bands is **not recommended and should be avoided.** Should additional hose be required, it may be obtained from AMSOIL, Inc. by ordering part number BP-230 by the foot.

1. (Oil supply hose) Measure the amount of hose (BP-230) you will need to run from the side port on the spin-on adapter (labeled **A**) to the port with arrow pointing **IN** on the filter mount, also labeled **A**. Additional length will be required to accommodate engine movement during operation. Also, consider how the hose will be routed. Make sure the hose does not contact any hot or moving surfaces or sharp edges. Insure a minimum bend radius of 2 1/4" is maintained at all corners. Also, bends in hose should not begin at hose fittings. See diagrams C and H for additional detail. **Note:** Insure hose has significant additional length to accommodate movement of engine. Note the need for optional 90° fitting.
2. Using a fine tooth hacksaw or chop saw, squarely cut the hose to the proper length.
3. Install hose fittings (BP-229) on both ends of the cut hose. Follow the instructions noted in diagram G. Tools required are one 7/8" wrench and one 15/16" wrench or vise. **Note:** Do not use any form of thread sealant anywhere on the BP-229 hose fittings. However, apply anti-sieze compound (BP-238) as noted in Diagram G.
4. Route the hose assembly as noted in D.1. and connect the hose fittings. Optional 90° fitting (BK-199) (long) or (BK-200) (short) may be installed at this time between the hose fitting and mount or spin-on adapter.
5. Using two 7/8" wrenches, tighten the hose fitting swivel nuts to 525 - 575 inch-pounds or from finger tight, rotate an additional 60° or 1/6 of a turn. **Note:** Do not use any form of thread sealant anywhere on the hose fittings. Again, applying anti-sieze compound as described in Diagram G.
6. (Oil return hose) Repeat steps D.1 through D.5. Connect hose at the center port on the spin-on adapter, labeled **B** and the port with the arrow point **Out**, on the filter mount, labeled **B**.

- Use plastic ties (BP-46) to secure hose in position and away from potential damage. Trim ties with side cutter. **Note:** Over tightening the plastic ties may cause the hose to collapse and restrict oil flow.
- Fill the selected Full-flow and By-pass filters with the same motor oil being used in the vehicle. Lubricate the filter gaskets with oil and spin filters onto mount. Tighten one full turn after filter gasket first contacts mount, back off $\frac{1}{8}$ ".

E. Start up procedures

- Check that all fittings and hoses are securely attached, and that the hoses are routed properly.
- Check engine oil level. Fill to full mark if necessary.
- With the equipment secured start the engine and immediately check oil pressure. **Note:** Pressure may initially take a moment or two to rise.

Caution: Carefully check for leaks at fittings, hoses and mount. If leaks are observed, **STOP ENGINE IMMEDIATELY**, repair leaks and continue.

- After engine has warmed, shut off and re-check engine oil level. Top off as necessary.
- Record equipment/operating hours and date of installation.

F. Periodic maintenance

- Periodic visual inspection of the fittings and hoses is recommended. Check for leaks, hose deterioration and cuts. Repair and/or replace as necessary.
- Refer to Recommended Filter Change Interval chart for servicing intervals.
- To change the filter elements:
 - Ensure engine is off and use caution as the engine, oil and filter may be hot and could result in an injury.
 - Using a filter wrench, remove the filter elements. Dispose of properly.
 - Clean the filter gasket contact areas on the mount with a clean, lint-free rag.
 - Lubricate the new filter gaskets with clean oil or grease.
 - Fill filters as full as possible with engine oil.
 - Screw on new filters, tighten one full turn after filter gasket contacts mount. Back off $\frac{1}{8}$ ".
 - Start engine and check for leaks.
 - Check engine oil level, fill as needed.
- Record equipment/operating hours for future reference.

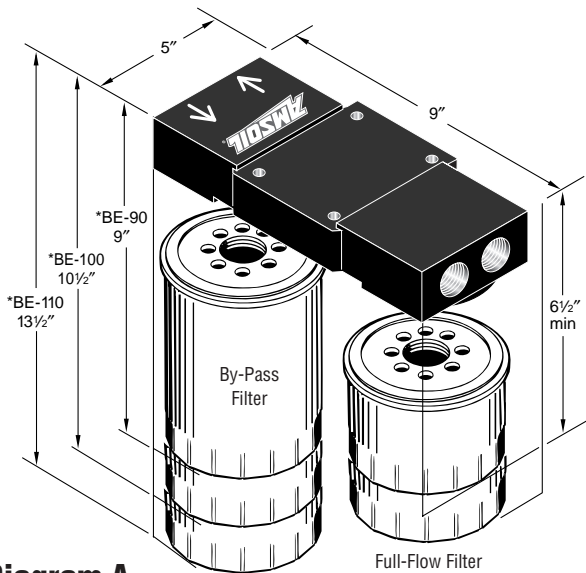
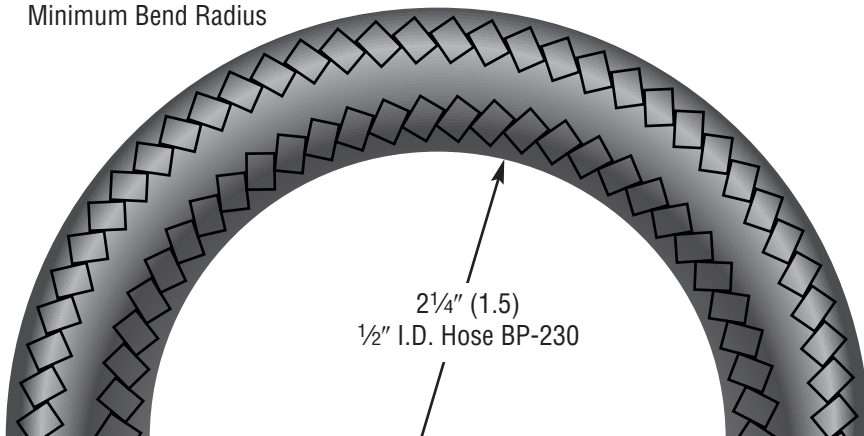

Diagram A

MINIMUM AREA NEEDED FOR
DUAL MOUNT AND SPIN-ON OIL FILTER ELEMENTS
* Mount and element heights plus 1-inch removal clearance

Diagram C

Minimum Bend Radius



Parts and assembly list

Item	Description	Qty.	Part No.
1.	Filter Mount Assembly	1	BK-194
1.	Allen Head Plug	1	BP-228
3.	1/4" 20 x 1" Hex Head Bolt	4	BP-234
4.	1/4" I.D. Washer	6	BP-237
5.	1/4" Self Locking Nut	8	BP-233
6.	90 degree Fitting 3/4"-16 Straight Thread	1	BP-231
7.	O- Ring Fitting Adapter	3	BP-232
8.	Hose Fitting	4	BP-229
9.	Hose 1/2" I.D. #10 USCG Approved	8	BP-230
10.*	Spin-On Adapter	1	BP-302
11.*	Adapter Retaining Nut 3/4"-16	1	BP-304
11.*	Adapter Retaining Nut 1 3/16"-16	1	BP-305
11.*	Adapter Retaining Nut 18mm x 1.5	1	BP-306
11.*	Adapter Retaining Nut 20mm x 1.5	1	BP-307
12.*	Gasket 2 1/2" I.D.	1	BP-196
13.*	O-Ring 3 1/8" I.D.	1	BP-162
14	Mounting Bracket top	1	BP-225
15	Mounting Bracket bottom	1	BP-226
16.	1/4"-20 x 1 1/2" Hex Head Bolt	4	BP-235
17.	1/4" Fender Washer	4	BP-236
18.*	Adapter Nut o-ring	1	BP-246
19.*	O-ring casting	1	BP-160
	Plastic Tie	4	BP-46
	Thread Sealant #271, 0.02 oz. Packet	1	BP-198
	Anti-seize compound	1	BP-238
	Instruction Sheet	1	BP-239
Optional Parts			
	90 degree fitting 1/2" JIC long	1	BK-199
	90 degree fitting 1/2" JIC short	1	BK-200
	Oil Sampling Kit	1	BK-13

*Included within the thread adapter kit sold separately.

Mounting Angle Diagram B

(Recommendations are the same right to left and front to back)
Mounting angle above horizontal is not recommended

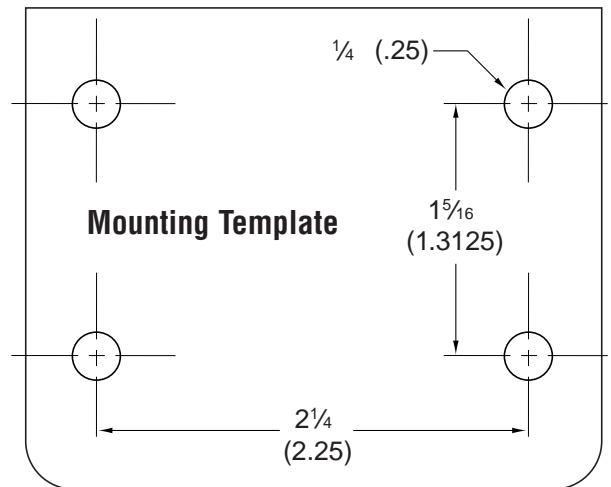
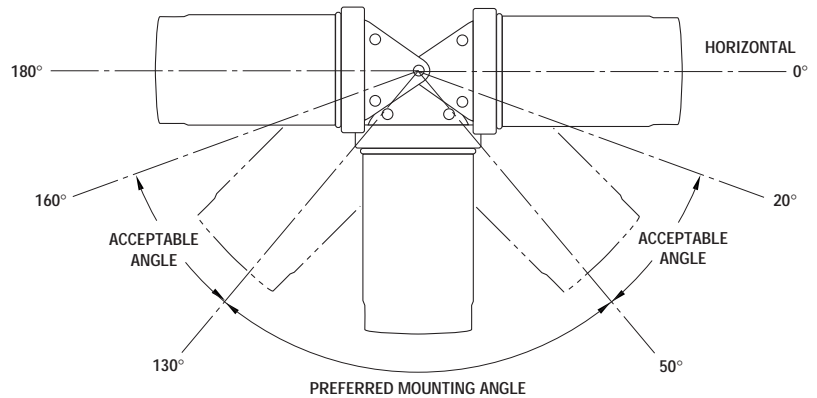
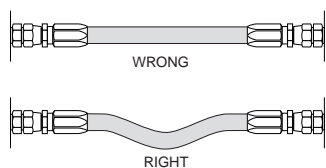
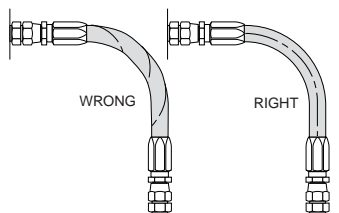

Diagram H Hose routing examples



1. Provide for length change

In straight hose installations allow enough slack in the hose line to provide for changes in length that will occur when pressure is applied. This change in length can be from +2% to -4%.



2. Avoid twisting and orient properly

Do not twist hose during installation. This can be determined by the printed layline on the hose. Pressure applied to a twisted hose can cause hose failure or loosening of connections.

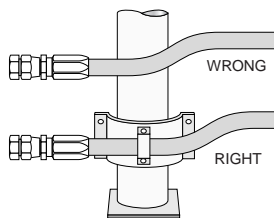

3. Protect from hazardous environment

Keep hose away from hot parts. High ambient temperature will shorten hose life. If you can not route it away from the heat source, insulate it.

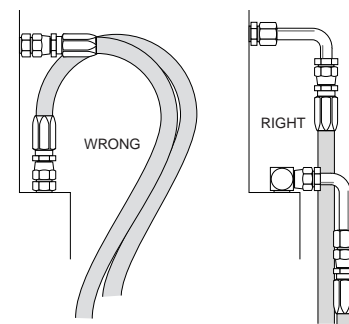

4. Avoid mechanical strain

Use elbows and adapters in the installation to relieve strain on the assembly, and to provide easier and neater installations that are accessible for inspection and maintenance.

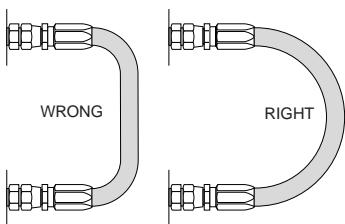

5. Use proper bend radius

Keep the bend radius of the hose as large as possible to avoid collapsing of the hose and restriction of flow. Follow catalog specs on minimum bend radii.

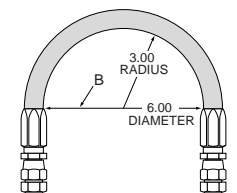

6. Use proper bend radius (cont.)

Maximum bend radius is measured on the inside bend of the hose. To determine minimum bend, divide the total distance between ends (B length) by 2. For example $8 \div 2 = 4$, minimum bend radius = 4.

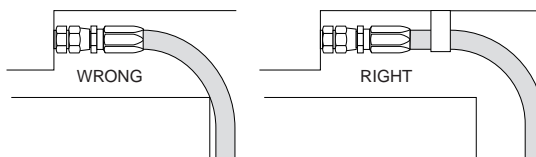

7. Secure for protection

Install hose runs to avoid rubbing or abrasion. Use clamps to support long runs of hose or to keep hose away from moving parts. It is important that the clamps do not allow the hose to move. This movement will cause abrasion and premature hose failure.

8. Avoid Improper Hose Movement

Make sure relative motion of the machine components produces bending rather than twisting of the hose. Hose should be routed so that the flex is in the same plane as the equipment movement.

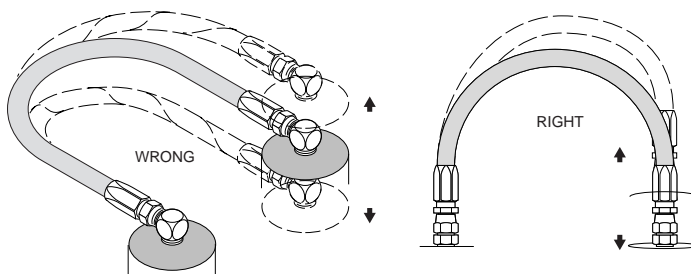

Recommended Filter Change Intervals

Follow these change intervals when using the By-Pass Oil Filter recommended for your size engine (i.e. BE-90 up to 9 qts.; BE-100 up to 15 qts.; BE-110 up to 21 qts.).

GASOLINE POWERED ENGINES

Engine Type	Type of Engine Oil Used	Expected Life of Oil Filters		
		AMSOIL By-Pass	AMSOIL Full Flow	OTHER Full Flow
Non-Turbo-charged Engines	AMSOIL Synthetic 15W-40 (AME), 10W-30 (ATM) and 0W-40 (AFF)	500 hours or 1 year	250 hours or 6 months	OEM Manufacturer's Recommended Oil Filter Change Interval
	Other AMSOIL Synthetic Motor Oils	300 hours or 1 year	150 hours or 6 months	OEM Manufacturer's Recommended Oil Filter Change Interval
	Premium Conventional Engine Oils	2 Times OEM Manufacturer's Recommended Oil Filter Change Interval	Vehicle OEM Manufacturer's Recommended Oil Filter Change Interval	OEM Manufacturer's Recommended Oil Filter Change Interval
Turbo-charged Engines	AMSOIL Synthetic 15W-40 (AME), 10W-30 (ATM) and 0W-40 (AFF)	300 hours or 1 year	150 hours or 6 months	OEM Manufacturer's Recommended Oil Filter Change Interval
	Other AMSOIL Synthetic Motor Oils	150 hours or 6 months	150 hours or 6 months	OEM Manufacturer's Recommended Oil Filter Change Interval
	Premium Conventional Engine Oils	2 Times OEM Manufacturer's Recommended Oil Filter Change Interval	OEM Manufacturer's Recommended Oil Filter Change Interval	OEM Manufacturer's Recommended Oil Filter Change Interval

DIESEL POWERED ENGINES Due to higher oil contamination levels in diesel engines and variance in fuel quality, maintenance intervals for the filter element and oil change intervals should be determined using oil analysis.

To order By-Pass Oil Filter Parts or oil sample kits, consult your AMSOIL Dealer or the AMSOIL Product Price List for your country. Most of these items are available from your AMSOIL Product Center.

BMK-18: PAGE TWO

(1) **BP-228**
ALLEN HEAD
PLUG

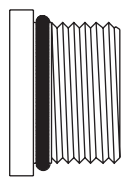

(1) **BP-231**
90° Fitting

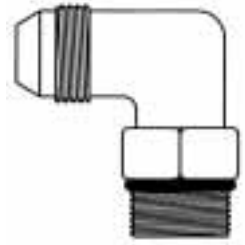

(1) **BP-75**
SMALL "O" RING
2 1/2" I.D.



(1) **BP-225**
MOUNTING
BRACKET
TOP

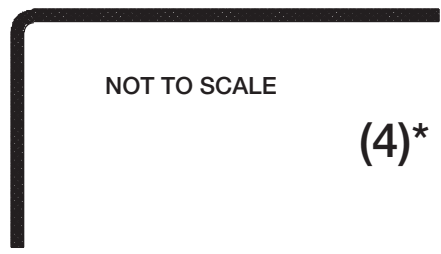

NOT TO SCALE

(4)* **BP-304** 3/4" - 16 Thread
BP-305 1 3/16" - 16 Thread
BP-306 18 mm x 1.5 Thread
BP-307 20 mm x 1.5 Thread
Adapter retaining nut

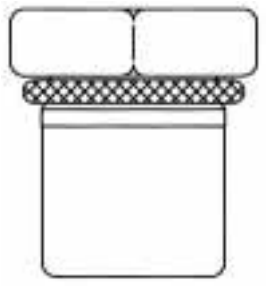

(1) **BP-226**
MOUNTING
BRACKET
BOTTOM

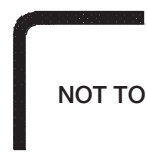

NOT TO SCALE

(1) **BP-246***
Adapter Nut "O" Ring
1 3/16" I.D.



(1) **BK-194**
FILTER MOUNT
ASSEMBLY

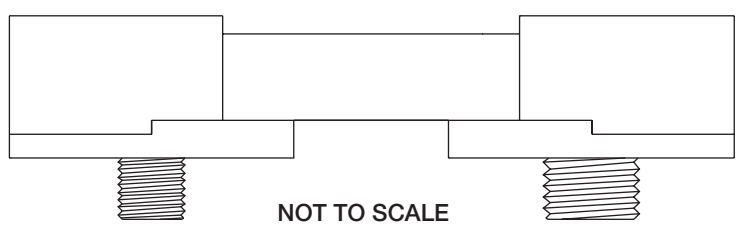

NOT TO SCALE

* Contained in thread adapter kits sold separately.

BMK-18 PARTS IDENTIFICATION SHEET

(4) BP-46 
 PLASTIC TIE

(6) BP-237 
 $\frac{1}{4}$ I.D. WASHER

(8) BP-233 
 $\frac{1}{4}$ NUT

(4) BP-234 
 $\frac{1}{4}$ X 1 BOLT

(1) BP-302 
 FILTER ADAPTER
 NOT TO SCALE

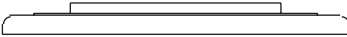
(1) BP-160* 
 "O" RING CASTING
 NOT TO SCALE

(1) BP-162* 
 LARGE "O" RING
 $3 \frac{1}{8}$ I.D.
 NOT TO SCALE

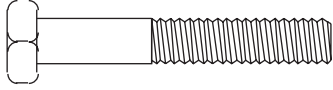
(4) BP-235 
 $\frac{1}{4}$ X 1 $\frac{1}{2}$
 BOLT

(4) BP-236 
 $\frac{1}{4}$ FENDER
 WASHER

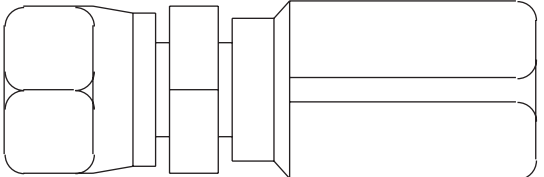
(4) BP-229 
 HOSE FITTING

(8) BP-230 
 $\frac{1}{2}$ I.D. HOSE

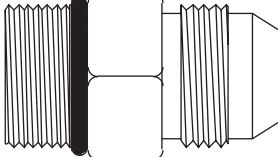
(3) BP-232 
 "O" RING
 FITTING
 ADAPTER

* Contained in thread adapter kits sold separately.